

**BOSCH**

Invented for life

Bosch SM Mega Power Plus

60588 - Maintenance Free / Calcium, Calcium Technology

Applications

Passenger Vehicles



Bosch Master Data

Short Order Part Number

60588

Bosch 10 Digit Part Number

0986A00251

EAN Barcode

4047023092472

Product Series

SM Mega Power Plus

Technology

Calcium, Calcium

Warranty Period

Refer www.boschaftermarket.com.au

Refer www.boschaftermarket.co.nz

Technical Information

Nominal Voltage

12V

Nominal Capacity (20HR)

105 AH

Reserve Capacity (RC)

190 Mins

Cold Cranking Amperes (CCA)

880 Amps

Case Size Dimension

Length

353 mm (13.89 inches)

Width

175 mm (6.89 inches)

Container Height

165 mm (6.49 inches)

Total Height (with Terminal)

190 mm (7.48 inches)

Approx Weight (Gross)

22.80 kg (50.16 lbs)

Terminal / Layout

(-+)

Container Material

Polypropylene

Lid Design

Labrynth Lid

Base Hold Down

B3

Product Dimension & Design

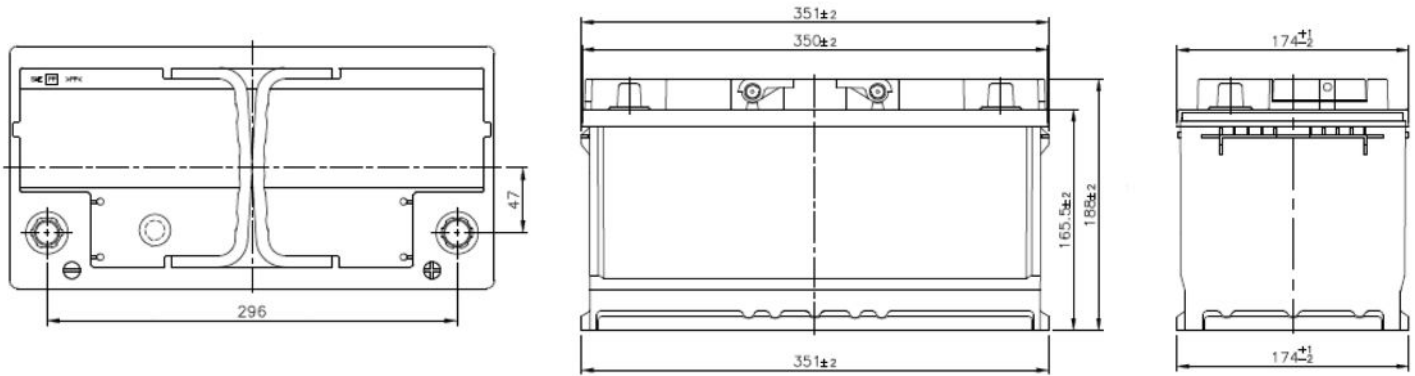

Product Performance Overview

Depth of Discharge Cycling Test

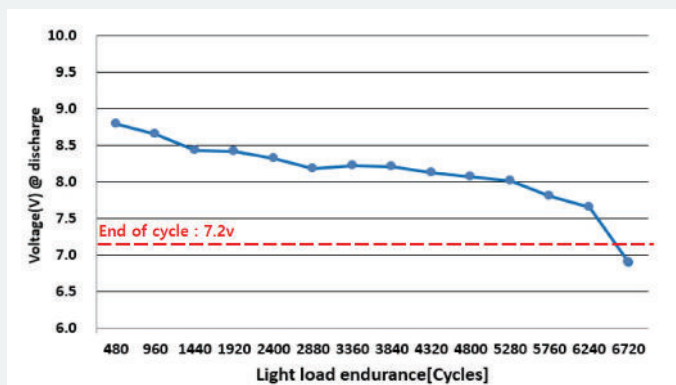

Discharge Characteristics Test

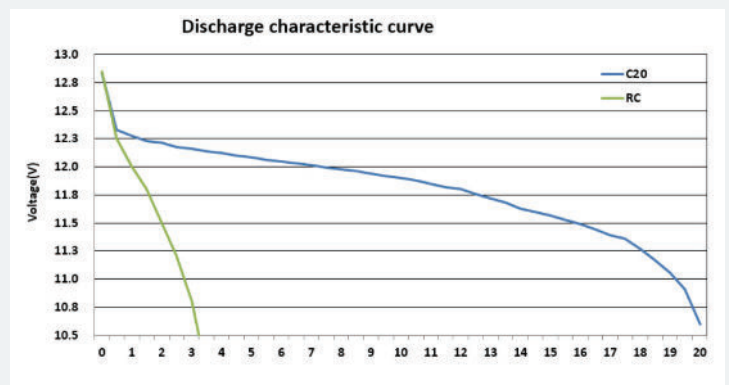

Your address for genuine Bosch quality:

Dealer stamp here: